

R202

Heating Area
24" X 24"

Propane Tank

- Operates of one 20LB horizontal tank



Regulator

- Adjustable regulator to control the temperature of the heaters.
- C.S.A. & C.G.A. approved propane regulator

Extend-able Handle

- Lifting handle extends for better maneuverability



Casters

- Rubber caster wheels with heat shield

Patented Cartridge System

- Easily replaceable HDE cartridge with bolt & nut attachment.
- Typical cartridge life is approximately 1500 hours.



*May show Options

**HEAT DESIGN
EQUIPMENT
INC.**

The Infrared People

R2D2

Heating Area
24" X 24"

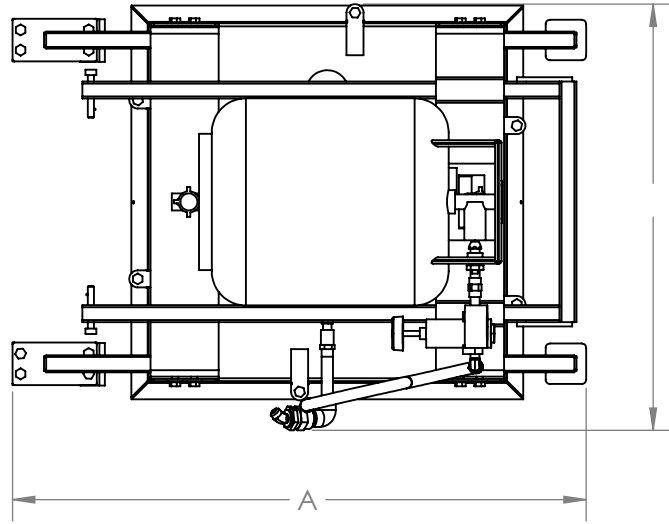

B

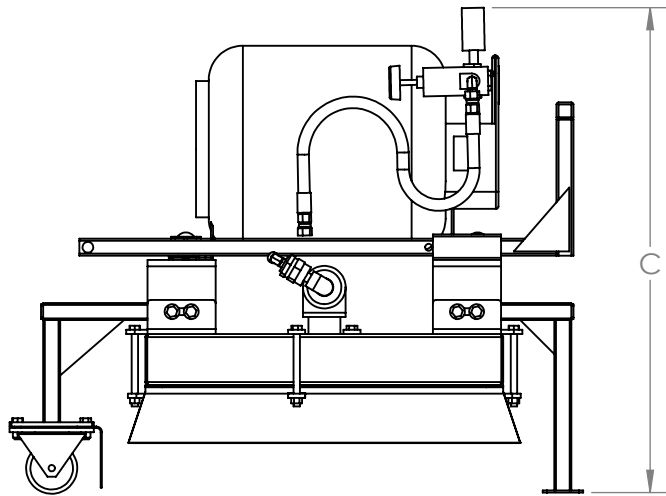
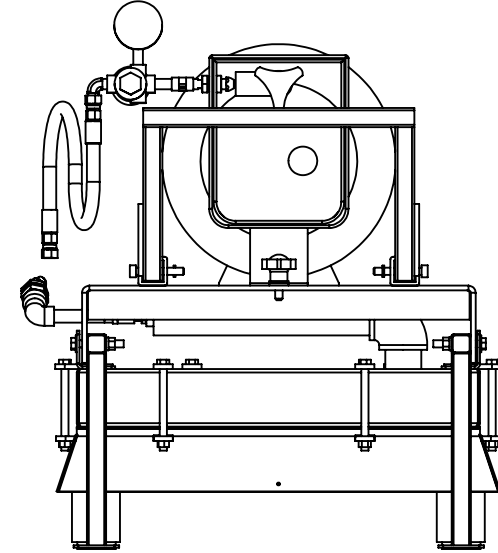

LETTER	DESCRIPTION	DIMENSION
A	OVERALL LENGTH	33-11/16"
B	OVERALL WIDTH	25"
C	OVERALL HEIGHT	28-1/2"

**HEAT DESIGN
EQUIPMENT
INC.**

The Infrared People