

# P300

Heating Area  
36" X 72"

WWW.ASPHALTHEATER.COM

## Stainless Steel Pipe

\*May show Options



## Regulator

- Adjustable regulator to control the temperature of the heaters.
- C.S.A. & C.G.A. approved propane regulator



## Propane Tank

- Operates of two 30 or 40LB LPG tanks
- Tanks are secured by a 2" heavy duty nylon strap

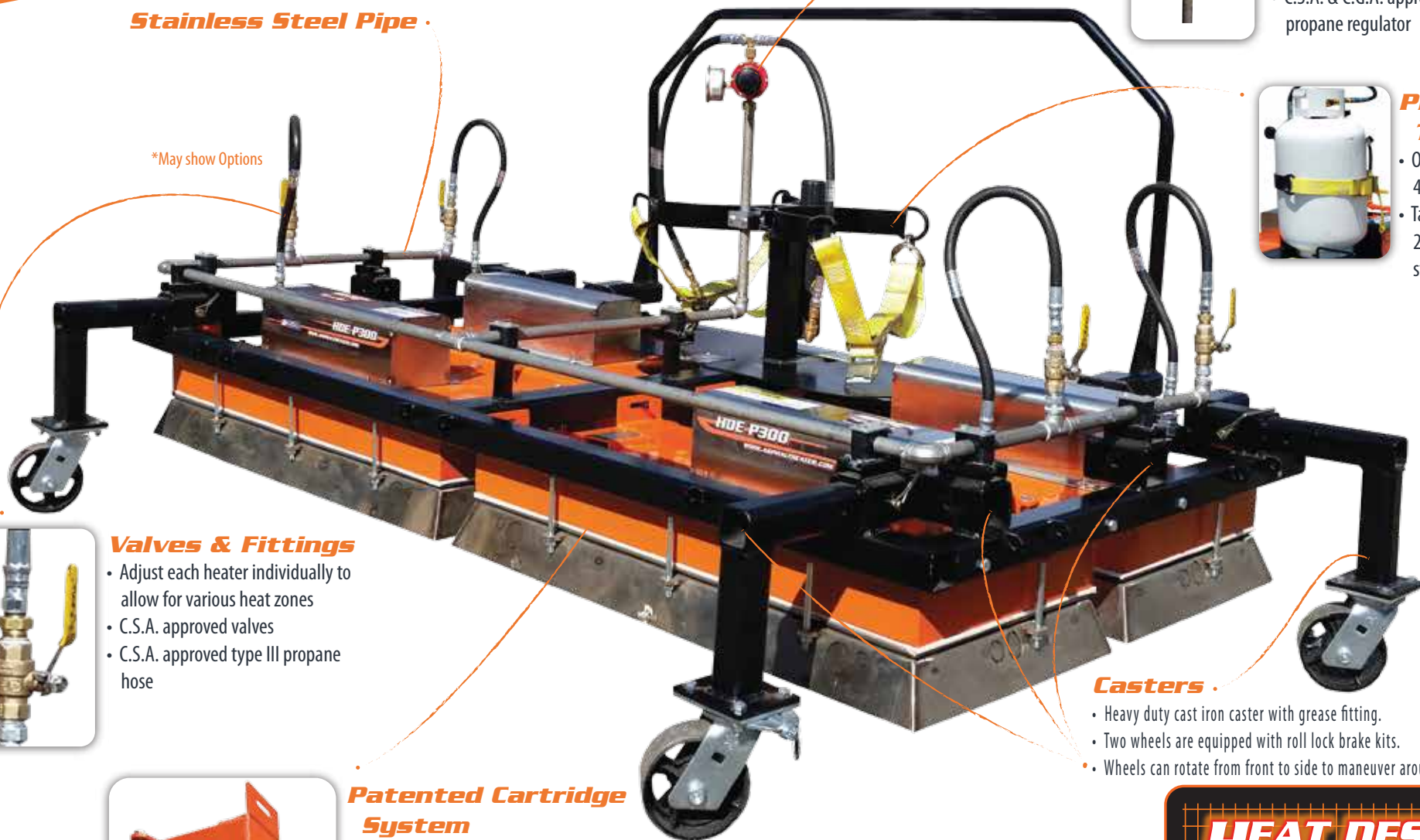

## Valves & Fittings

- Adjust each heater individually to allow for various heat zones
- C.S.A. approved valves
- C.S.A. approved type III propane hose



## Patented Cartridge System

- Easily replaceable HDE cartridge with bolt & nut attachment.
- Typical cartridge life is approximately 1500 hours.



## Casters

- Heavy duty cast iron caster with grease fitting.
- Two wheels are equipped with roll lock brake kits.
- Wheels can rotate from front to side to maneuver around objects.

**HEAT DESIGN  
EQUIPMENT  
INC.**

*The Infrared People*

# P300

Heating Area  
36" X 72"

WWW.ASPHALTHEATER.COM

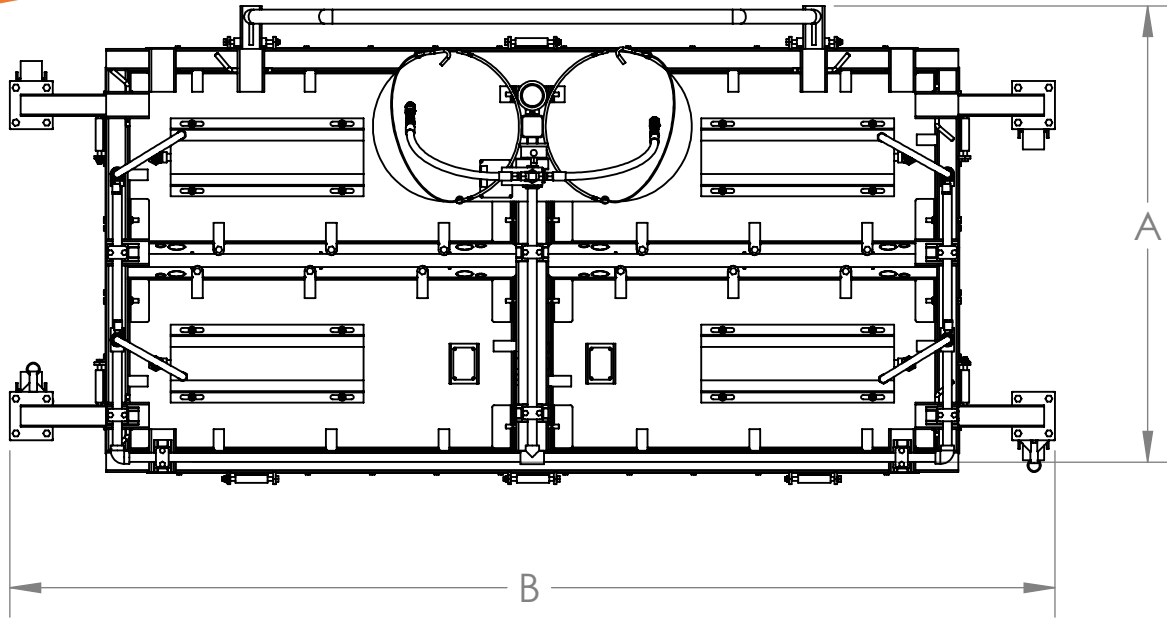

LETTER	DESCRIPTION	DIMENSION
A	OVERALL LENGTH	45-5/8"
B	OVERALL WIDTH	97-1/2"
C	OVERALL HEIGHT	42-3/16"

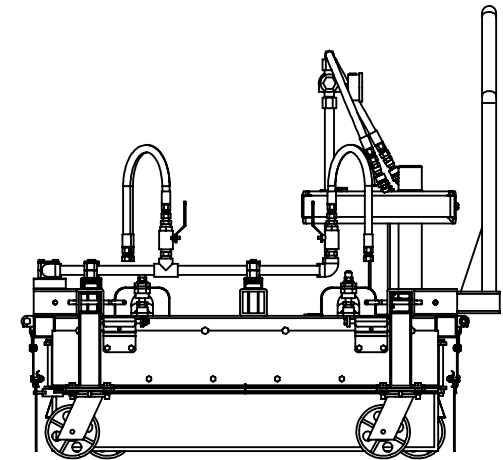
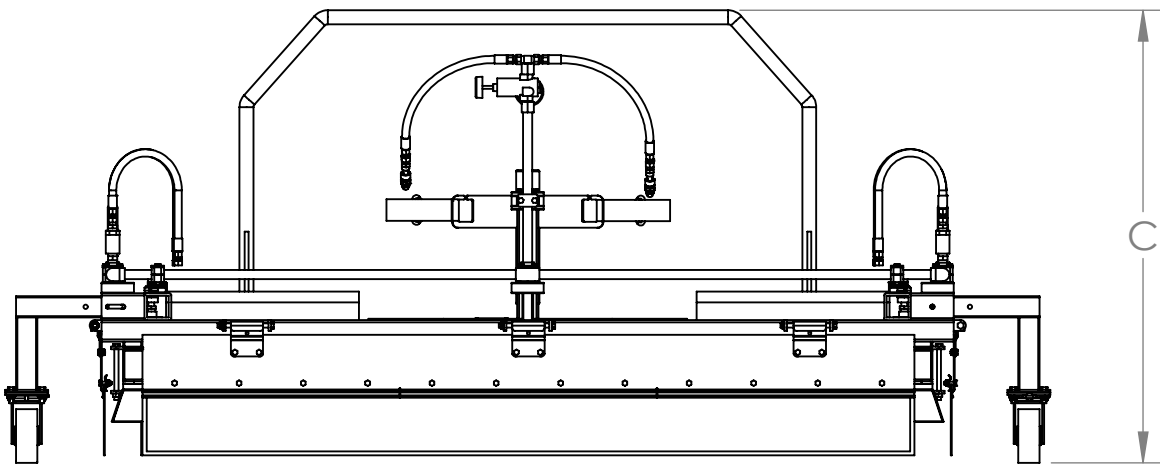

**HEAT DESIGN  
EQUIPMENT  
INC.**

*The Infrared People*