

PS-3-150 MINI IR HEATER

FEATURING OUR NEW: HeatLink system seamlessly connects multiple heaters, to form a larger heating area



Features & Benefits

- 150,000 BTU Infrared heater with simple cartridge replacement
- Bolt on hinge to easily covert to lineal heater in minutes
- Adjustable regulator with integrated pressure gauge to control temperature
- Venturi propane mixing system eliminates batteries and blowers
- Easily connects to two 40lb vapor propane tanks with 8 to 10 hours of runtime
- Adjustable handlebars for easy moving and transportation
- Optional wind skirts to contain heat
- Universal caster system

Infrared Asphalt Heaters possess the ability to revive worn-out asphalt. By utilizing advanced infrared technology, these heaters have the power to heat and soften damaged areas, in just 10 minutes, these heaters can restore the asphalt to its original mixing temperature, enabling the asphalt to be reworked and compacted, resulting in a long lasting repair. To accommodate larger work areas, HeatLink system allows for the seamless connection of multiple heaters. With this innovative solution, you can now connect multiple heaters both in width and length.

Productivity

- Reheats and reworks affected areas in place
- Easily repair potholes, bird baths, cracks, seams, and other surface imperfections
- Penetrates surface asphalt without burning

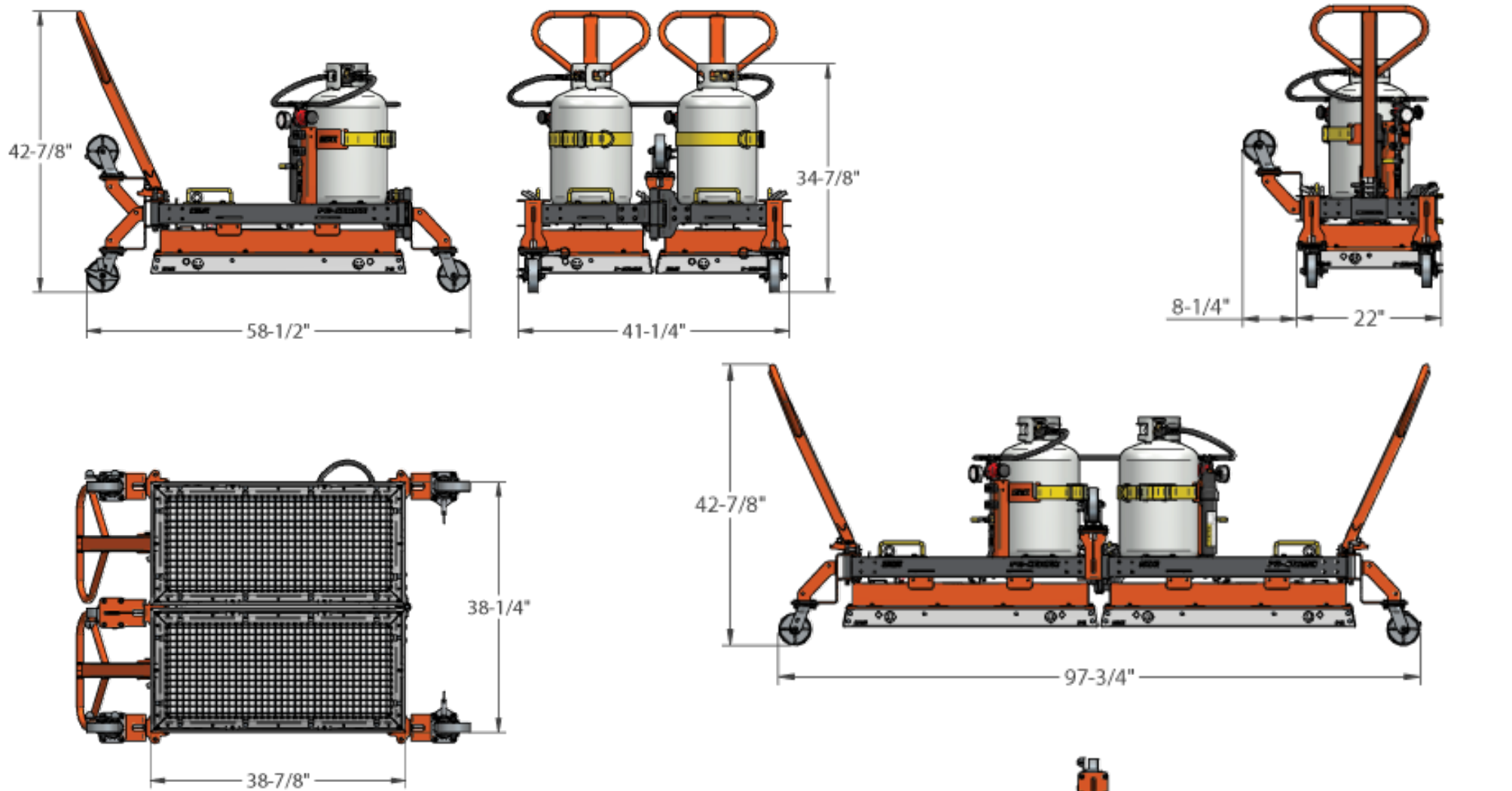

Heating Area (inches)	38-1/4 x 39
Linear Heating Area (inches)	78-1/4 x 19
Assembled Dimensions (inches)	42-7/8 x 58-1/2 x 41-1/4
Linear Dimensions (inches)	42-7/8 x 97-3/4 x 22
Weight (lbs)	315
Fuel Type	Propane Vapor
Max fuel Pressure	45
Burner Type (BTU)	150000
Heater Cartridge	Ceramic

